

| | | | | |
|-------|---------------|------|-----------|---------|
| RevNo | Revision note | Date | Signature | Checked |
|-------|---------------|------|-----------|---------|

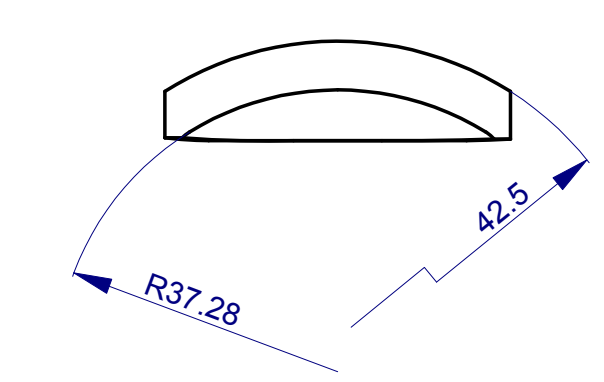
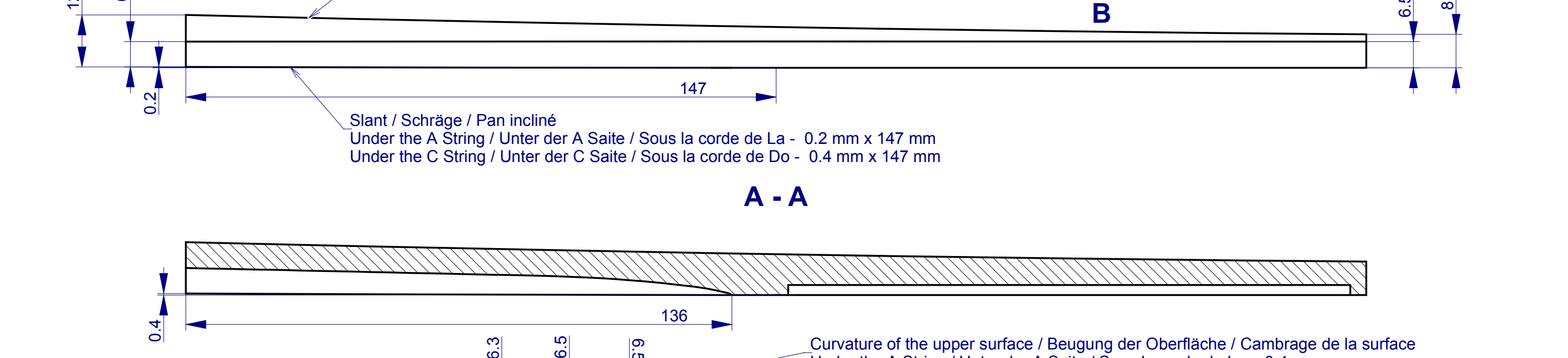
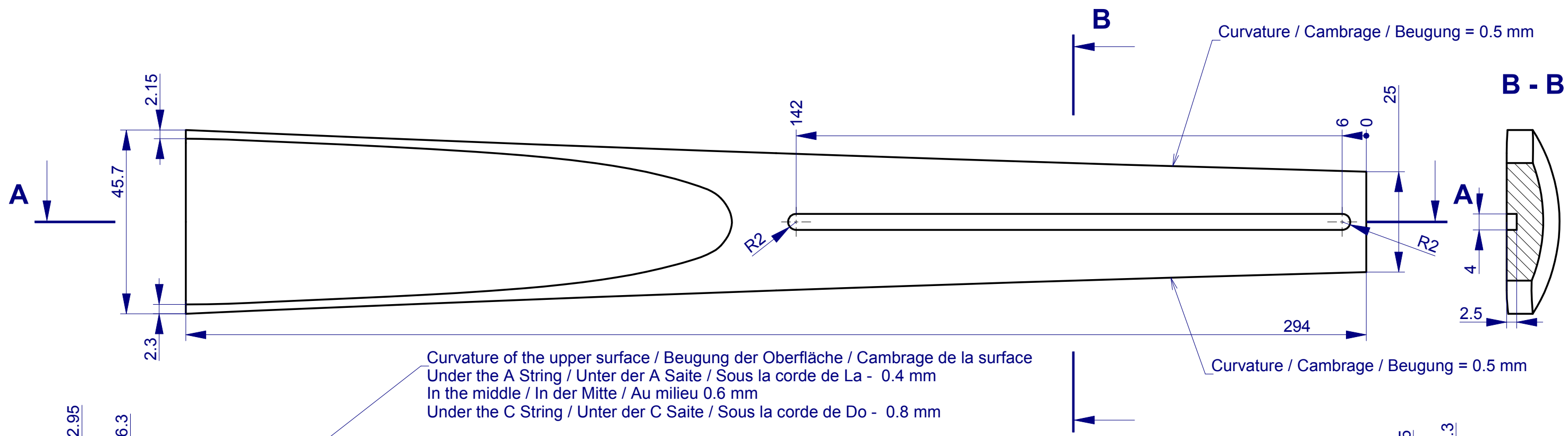

| | | | | | |
|---------------------|------------|--|------------------------|---------------------|--------------|
| Itemref | Quantity | Title/Name, designation, material, dimension etc | Article No./Reference | | |
| Designed by PHEN | Checked by | Approved by - date | File name | Date 22 oct 2016 | Scale 1:1 |
| Corène | | | Alt-Form_A-4_4-Fin-Std | | |
| | | | Génération 3 | Edition | Sheet |

1

2

3

4

5

6

| | | | | |
|-------|---------------|------|-----------|---------|
| RevNo | Revision note | Date | Signature | Checked |
|-------|---------------|------|-----------|---------|

A

A

B

B

C

C

D

D

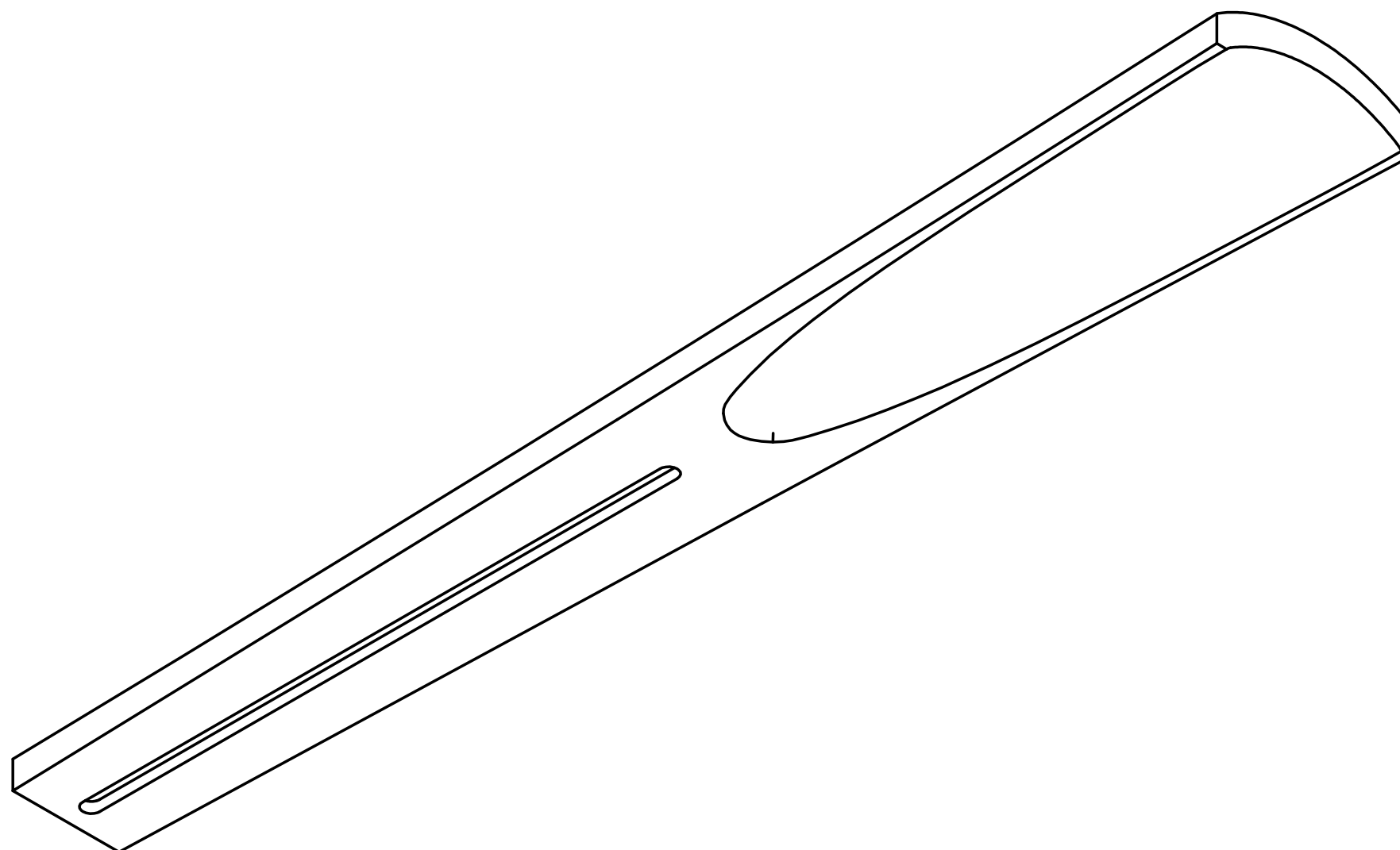

| | | | | | |
|---------------------|------------|--|------------------------|---------------------|-----------------|
| Itemref | Quantity | Title/Name, designation, material, dimension etc | Article No./Reference | | |
| Designed by PHEN | Checked by | Approved by - date | File name | Date 22 oct 2016 | Scale 1:1 |
| Corène | | | Alt-Form_A-4_4-Fin-Std | | |
| | | | Génération 3 | | Edition v 10 |

1

2

3

4

5

6

